

**Assembling the HANGING BAR STEP 4**

1. Plug one end of the HANGING BAR SUPPORT POLE (L) into each of the smaller holes in the POLE STOPS (P).
2. Plug the HANGING BAR CROSS POLES (M) into the larger holes in the POLE STOPS (P). This now creates the Hanging Bar Assembly. The larger POLE being on top with the POLE STOP tabs facing up to keep hangers from sliding off.
3. Push the POLE LOCKS (N) onto the center posts at the top of the SORTER HANDLES (G). The thumb lock is at the top.
4. Hold with both hands the SUPPORT POLES for the Hanging Bar Assembly and slide the poles into the POLE LOCKS and lock into place using your thumb to press the lever tightly onto the support poles. The poles can be adjusted in height by using the pole locks to adjust.

NOTE: If the SUPPORT POLES do not slide easily the POLE STOPS may not be pushed in tight enough toward each other.

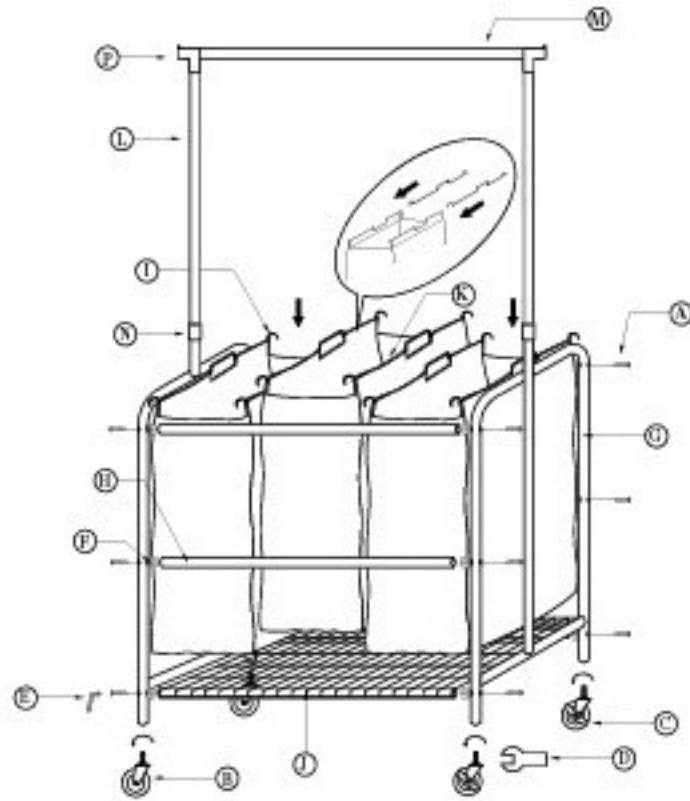

# 3 Bag Laundry Sorter Instructions



## Customer Service

Toll free: 800-323-5565  
Monday through Friday 9:00 AM - 4:30 PM (PST)



Torrance, CA 90501 USA

[www.sevilleclassics.com](http://www.sevilleclassics.com)

1. Slide WIRE HANDLE (I) through the pocket on the top of the BAG (K) so that the handle is up and the black coated end point down.
2. Slide another WIRE HANDLE (I) through the other pocket.
3. Holding both handles together lift the bag into the SORTER and onto the top CROSS SUPPORTS (H). Spread the handle wide and the BAG is now secure.
4. Repeat for the other two Bags.

### Assembling the HANGING BAGS STEP 3

1. Turn the SORTER over on its side.
2. Screw the two WHEELS (B) into the threaded holes on the ends of the SORTER HANDLES.
3. Screw the two LOCKING WHEELS (C) on the opposite side of the non locking WHEELS (B) and into the other SORTER HANDLE.
4. Turn the SORTER upright.
5. Place WIRE SUPPORT PANEL (J) between the two SORTER HANDLES and onto the bottom two CROSS SUPPORTS. It will snap in place.

### Assembling the WHEELS STEP 2

1. Place the SORTER HANDLE (G) upright as shown on the drawing on clean flat surface.
2. Push BOLT (A) through the bottom hole on the SORTER HANDLE.
3. Place the CROSS SUPPORT GASKET (F) over the bolt so that the crescent shape side wraps around the tubing.
4. Place CROSS SUPPORT (H) so that the BOLT (A) will thread into the end of the CROSS SUPPORT.
5. Screw the BOLT into the CROSS SUPPORT using ALAN WRENCH (E). Do not tighten completely.
6. Repeat using the other SORTER HANDLE on the other side of the CROSS SUPPORT.
7. Repeat the process until all 6 CROSS SUPPORTS are in place.
8. After all are in place hand tighten all the BOLTS.

### Assembling the SORTER STEP 1

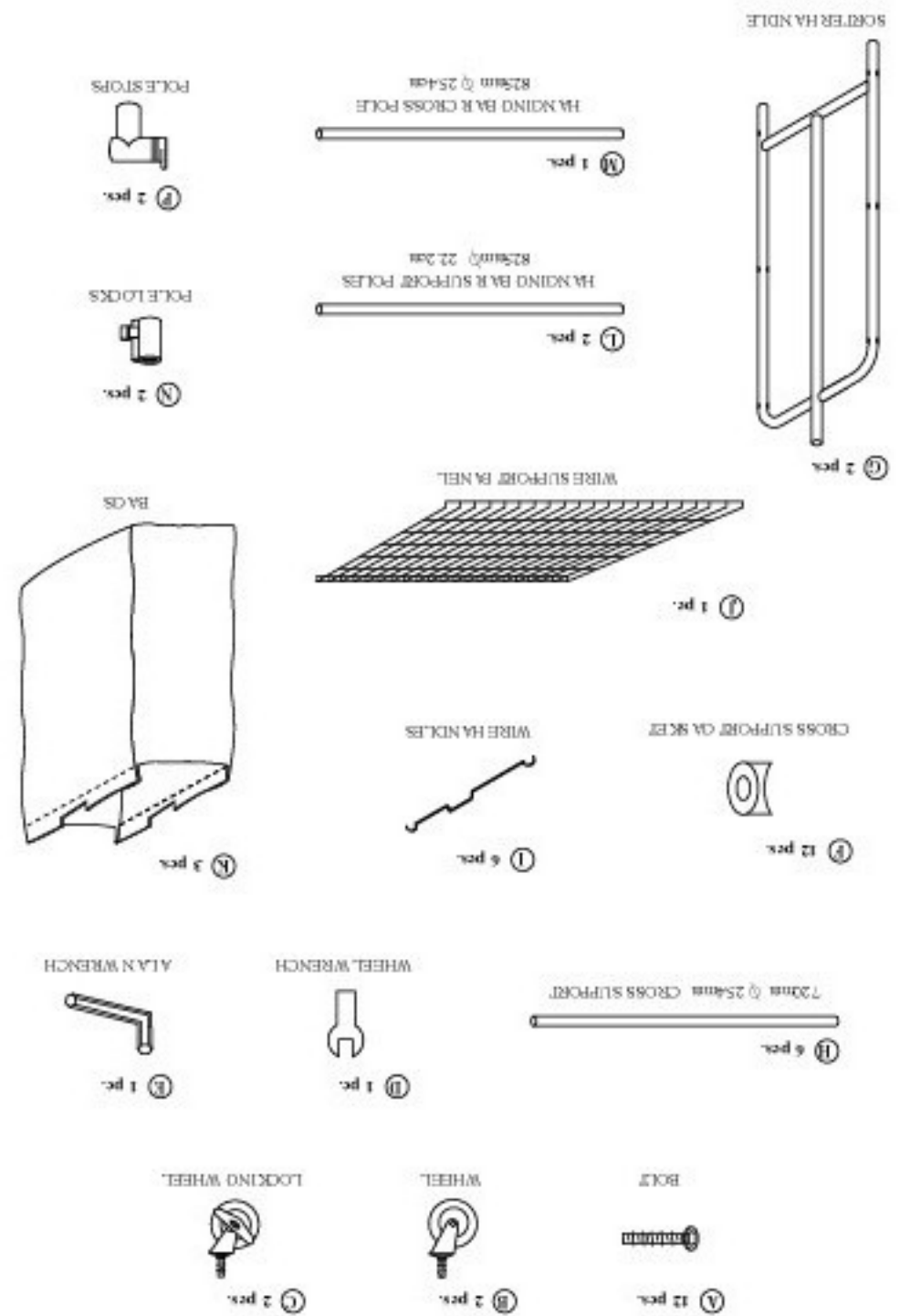

2005.07.19-16165